

Ref. : JT4243 .pas

Rev. : B

Date : 07/06/2017

Page : 1/1

JOINT DE DEMONTAGE PN16

JT4243



Tecofi'
VALVE DESIGNER - FRANCE

APPLICATION

Usage général : Montage et démontage facile de robinetterie destinée à l'eau et l'eau potable...

CARACTERISTIQUES GENERALES

Gamme : du DN 50 au DN 2000.
Raccordement PN16.

CONSTRUCTION

6	-	Rondelle	Acier	Dacromet
5	-	Tige filetée	Acier 4.8	Dacromet
4	1	Bague d'étanchéité	EPDM	WRAS
3	1	Bride de maintien	Fonte ductile EN-GJS-500-7	DIN: GGG50 ASTM: A536 70-50-05 BS: 500/7
2	1	Bride courte	Fonte ductile EN-GJS-500-7	DIN: GGG50 ASTM: A536 70-50-05 BS: 500/7
1	1	Bride longue	Fonte ductile EN-GJS-500-7	DIN: GGG50 ASTM: A536 70-50-05 BS: 500/7
Rep.	Nb.	Désignation	Matière	



DIMENSIONS

DN		Δ L	L1	D5	D4	n-m	Epaisseur bride	Poids (kg)
mm	inch							
50	2"	50	215	165	125	M16*330*4	16+3	9,9
65	2 1/2"	50	215	185	145	M16*330*4	16+3	11,4
80	3"	50	225	200	160	M16*340*8	16+3	15,7
100	4"	50	225	220	180	M16*340*8	16+3	18,6
125	5"	50	225	250	210	M16*340*8	16+3	27,5
150	6"	50	245	285	240	M20*350*8	16+3	29
200	8"	50	235	340	295	M20*350*12	16+3	39,4
250	10"	50	250	400	355	M24*380*12	19+3	55
300	12"	50	265	455	410	M24*400*12	20.5+3	69,4
350	14"	50	265	520	470	M24*410*16	22.5+3	89
400	16"	50	300	580	525	M27*430*16	24+3	115
450	18"	50	295	640	585	M27*450*20	26+3	158,2
500	20"	50	295	715	650	M30*460*20	27.5+3	198
600	24"	50	315	840	770	M33*500*20	31+3	270
700	28"	50	325	910	840	M33*500*24	34.5+3	296
800	32"	50	340	1025	950	M36*530*24	38+3	386
900	36"	50	350	1125	1050	M36*530*28	41.5+3	456
1000	40"	50	360	1255	1170	M39*570*28	45+3	582
1200	48"	50	370	1485	1390	M45*620*32	52+3	740
1400	56"	50	380	1685	1590	M45*630*36	55+3	1360
1500	60"	50	400	1820	1710	M52*665*36	57+3	1510
1600	64"	50	400	1930	1820	M52*700*40	60+3	1690
1800	72"	50	420	2130	2020	M52*730*44	65+3	2500
2000	80"	50	440	2345	2230	M56*730*48	69+3	2930

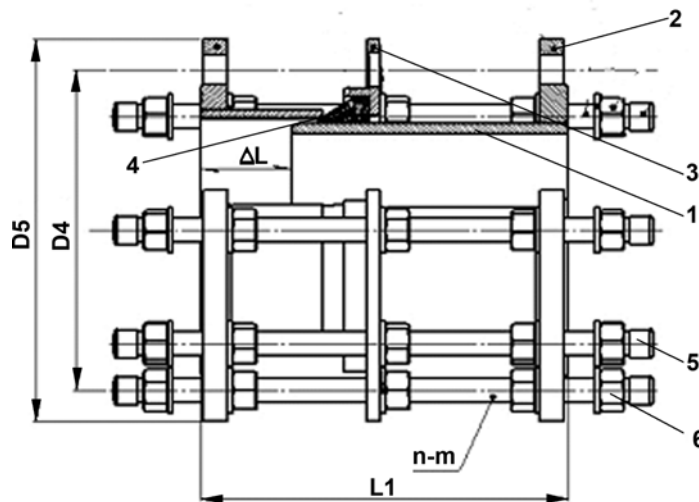

CONDITIONS DE SERVICE

Pression de service maxi: 16 bar
Température de service maxi: +4°C / +110°C

AGREMENT ET NORMES

Pression de test selon: EN12266-1:
Corps: 24 bar

Montage avec brides EN 1092-2 PN16

Peinture époxy RAL 5015, épaisseur 250 microns - WRAS

TECOFI France - 83, Rue Marcel Mérieux 69960 Corbas - FRANCE
Tél. +33 (0) 4 72 79 05 79 - Fax +33 (0) 4 78 90 19 19 / +33 (0) 4 72 79 05 70
Adresses e-mail : sales@tecofi.fr / Site web : www.tecofi.fr